

3M™ Digital Projector X66

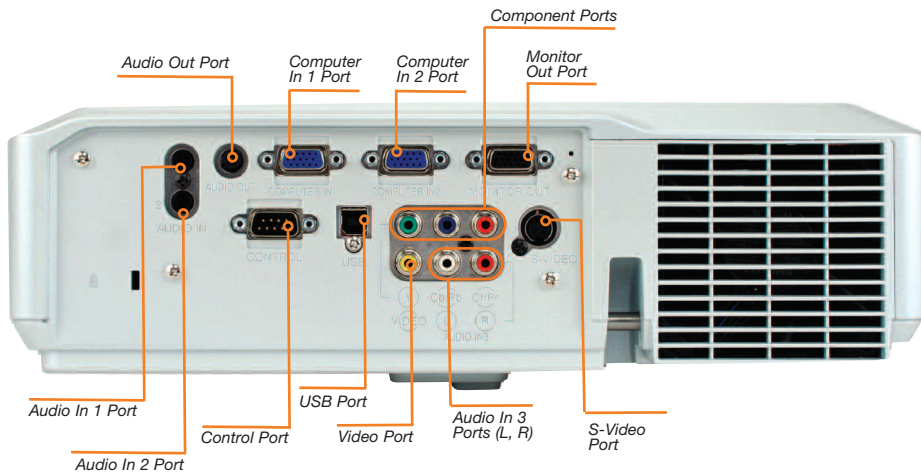

The 3M Digital Projector X66, with its 3000 lumens* and crisp, data and video image display, is the ideal projector for larger classrooms, conference rooms, executive boardrooms, hotel meeting and ballrooms or even small auditorium-designed rooms. The native 4:3 aspect ratio delivers data slides in a clear XGA, 1024 x 768 resolution, and you can easily switch the input to a 16:9 format for popular DVD formats. The Automatic Vertical Digital Keystone Adjustment feature takes the guess work out of adjusting your image, and the full connectivity makes it easy to use multimedia equipment to fit your presentation needs.



Features

- 3000 lumens*
- XGA (1024 x 768) resolution
- Full Connectivity
- Automatic Vertical Digital Keystone
- Easy Lamp Replacement
- 4 Security Lock Options
- Aspect Ratio: 4:3 Native; 16:9 Supported
- Advanced Personalization Features
- Quick Power On Mode
- Soft Carry Case Included
- 3-Year Standard Warranty

**indicates maximum lumens rating*



1-800-328-1371
www.3m.com/meetings



3M™ Digital Projector X66 Specifications & Accessories

Optical

Resolution:	Native: True XGA (1024 x 768) Maximum: UXGA (1600 x 1200)
Imager set:	0.63", P-Si TFT Panel
Aspect Ratio:	4:3 Native and 16:9 Supported
Colors:	16.7 Million True Colors (24 bit)
Brightness:	3000 lumens (maximum rating)
Contrast Ratio:	400:1
Projection Lens:	F1.6-1.8 (f=19 - 23 mm)
Screen Size (range):	30-350"
Zoom / Focus:	Manual
Zoom Ratio:	1.2:1
Optional Lenses:	NA
Lamp:	UHB 220W (Normal Mode), 172W (Whisper)
Lamp Life:	2000 Hours (Normal Mode), Up to 3000 Hours (Whisper Mode)

System Specifications

Video Compatibility:	NTSC, NTSC 4.43, PAL, PAL-M, PAL-N, SECAM
SDTV/HDTV:	525i (480i), (525p) 480p, 625i (576i), 750p (720p@60Hz), 1125i (1080i@60Hz)
Computer Resolution Compatibility:	640 x 480 (VGA), 800 x 600 (SVGA), 1024 x 768 (XGA), 1280 x 1024* (SXGA), 1400 x 1050* (SXGA+), 1600 x 1200* (UXGA), 832 x 624 (MAC 16") *Resolution Digitally Compressed
Digital Keystone Correction:	Vertical: +/- 30°
Audio:	1 x 6W
Startup Screen:	Customizable
Noise Level:	Normal 36dB; Whisper 30dB
Horizontal Scan:	31.5 - 106 kHz
Vertical Scan:	56-120 Hz
Power Consumption:	320W
Power Supply: Universal:	100-120V/220-240V, 50/60 Hz
Regulatory Approvals:	UL, cUL, FCC Part 15 Subpart B Class B, EN60950-1, CE
Operating Temperature:	41° - 95° F (5° ~ 35° C)
Storage Temperature:	-4° - 140° F (-20° - 60° C)
Altitude:	Sea Level to 6000 Ft. (1,829 m)

Size

Dimensions (W x H x D):	13.4 x 3.94 x 10.6 In. (340 x 100 x 270 mm)
Weight:	7.8 lbs / 3.5 Kg

Technical Support

- Free unlimited software downloads and updates available on our website at www.3m.com/meetings
- Toll-free 24/7 Technical Support by calling **800.328.1371**

Specifications subject to change without notice.

3M and the 3M logo are trademarks of 3M Company. Used under license in Canada. All other trade names referenced are the service marks, trademarks, or registered trademarks of their respective companies.

© 3M 2008. All Rights Reserved. V1.31.08

3M Projection Systems

Building A 147-5N-01
6801 River Place Blvd.
Austin, TX 78726-9000

3M Canada

P.O. Box 5757
London,
Ontario, Canada
N6A 4T1

3M Mexico, S.A. de C.V.

Apartado Postal 14-139
Mexico, D.F. 07070
Mexico

Hg — LAMP CONTAINS MERCURY. Manage in accord with disposal laws. See www.lamprecycle.org or call 1-800-328-1371 (USA), 1-800-364-3577 (Canada). For product disposal see www.eiae.org (USA) or www.epsc.ca (Canada).

Screen Size (Diagonal)	Image Size 4:3		Image Size 16:9	
	Projection Distance		Projection Distance	
	Minimum (m)	Maximum (m)	Minimum (m)	Maximum (m)
40" (1.0)	46" (1.2)	56" (1.4)	50" (1.3)	61" (1.5)
60" (1.5)	70" (1.8)	84" (2.1)	76" (1.9)	91" (2.3)
100" (2.5)	117" (3.0)	140" (3.6)	127" (3.2)	153" (3.9)
150" (3.8)	176" (4.5)	211" (5.4)	192" (4.9)	230" (5.8)
200" (5.1)	235" (6.0)	282" (7.2)	256" (6.5)	307" (7.8)
300" (7.6)	352" (9.0)	423" (10.8)	384" (9.8)	461" (11.7)

Note: These sizes are ±10 percent. This is due to variations in the manufacture of the lens. If you are close to one of the endpoints you should verify with your unit that the image is the proper size at the proper distance.

Warranties

See www.3m.com/us/meetings/warranties for details on warranties.

Projector:	3 Years Standard
Lamp:	90 Days or 180 Hours, Remainder of 1 Year Prorated
Optional Coverage:	<i>Ultra Value Warranty Enhancement</i> – Includes free lamp, free loaner while unit is being repaired and expedited service. Not available outside U.S.

Connections

Computer

- 3 - Analog RGB (2 inputs, 1 output)
- 1 - USB Mouse
- 1 - Serial Control

Video

- 1 - Composite
- 1 - S-Video
- 1 - Component

Audio in/out

- 2 - Mini Stereo Jack Audio In
- 1 - RCA Audio In (Red/White)
- 1 - Audio Out (Audio Output is shared with Computer and Video Inputs)

Accessories Included

- Power Cords (US, UK, Europe)
- VGA/RGB Cable
- RCA Video/Audio Cable
- Remote Control (with 2 AA batteries)
- Multi-language Operator's Guide CD
- Soft side carry case



Optional Accessories

- Ultra Value Enhanced Warranty [U.S. Only] 78-6969-9919-8
- Lamp Replacement Kit (LKX66) 78-6969-9917-2
- Universal Ceiling Mount 78-6969-9874-5
- Soft Rolling Bag 78-6969-8926-4

Important Notice

All statements, technical information, and recommendations related to 3M's products are based on information believed to be reliable, but the accuracy or completeness is not guaranteed. Before using this product, you must evaluate it and determine if it is suitable for your intended application. You assume all risks and liability associated with such use. Any statements related to the product which are not contained in 3M's current publications, or any contrary statements contained on your purchase order shall have no force or effect unless expressly agreed upon, in writing, by an authorized officer of 3M.

Warranty; Limited Remedy; Limited Liability

This product will be free from defects in material and manufacture for a period of 3 years or 2500 hours from the date of purchase. 3M MAKES NO OTHER WARRANTIES OR CONDITIONS INCLUDING, BUT NOT LIMITED TO, ANY IMPLIED WARRANTY OR CONDITION OF MERCHANTABILITY OR FITNESS FOR A PARTICULAR PURPOSE. If this product is defective within the warranty period stated above, your exclusive remedy shall be, at 3M's option, to replace or repair the 3M product or refund the purchase price of the 3M product. Except where prohibited by law, 3M will not be liable for any indirect, special, incidental or consequential loss or damage arising from this 3M product, regardless of the legal theory asserted.